

CLEARVIEW RAILING INSTALLATION GUIDE

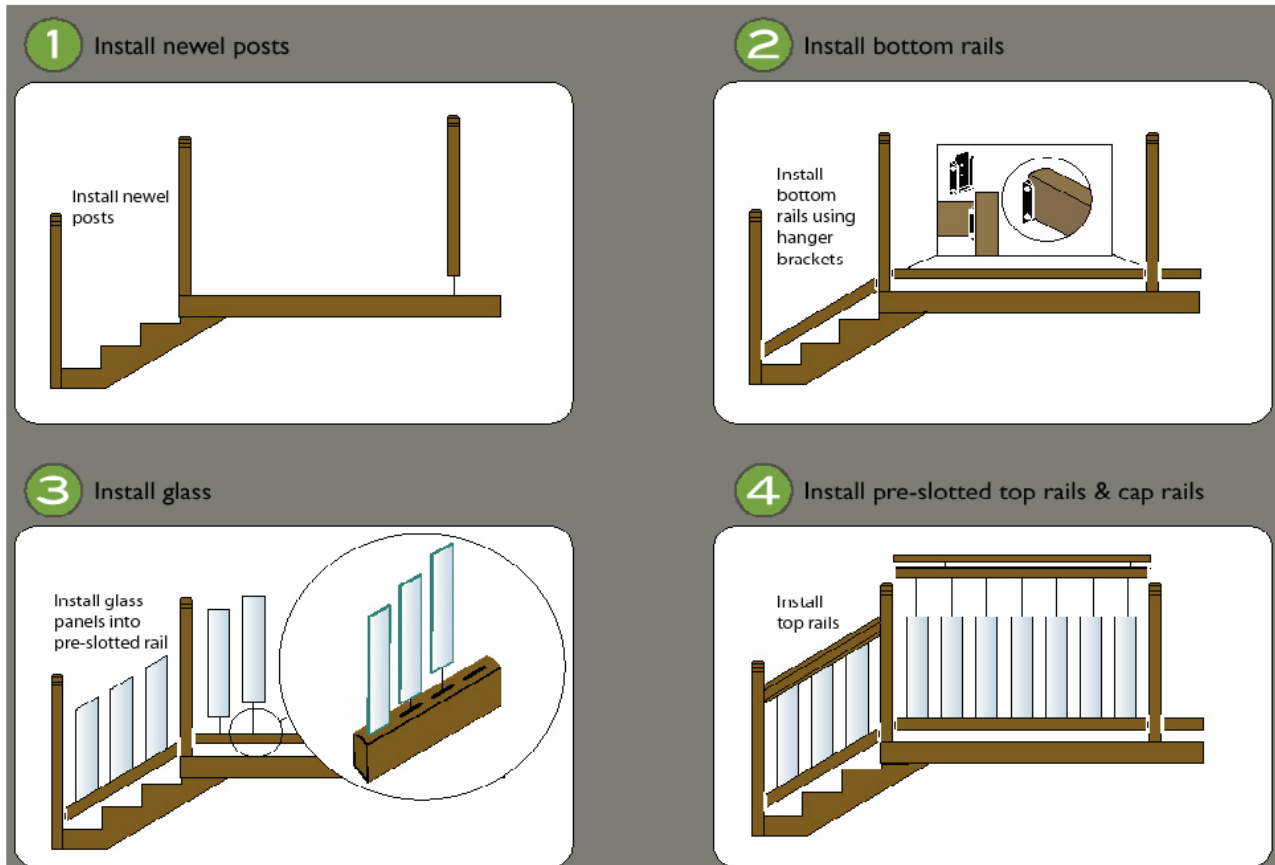

This document is a detailed step-by-step installation guide for the Clearview rail system.

These instructions may not cover all scenarios that may arise. Before beginning your installation take time to read all instructions thoroughly. A fundamental understanding of carpentry and a basic knowledge of power tools is essential. Please call our technical support line for any assistance required @ 1-800-667-8247.

Building codes are constantly changing and they can vary by province, state, county, city, town, and/or borough. In order to learn which codes are being used and how they will affect you and your construction project, contact your local building inspection department, office of planning and zoning, and/or department of permits.

1

Step 1 Install Newel Posts

- A) Set posts to accommodate required rail lengths. See detail 1-5, 1-6 for post attachment methods. Considering your rail height, posts may be trimmed to a desirable post height.

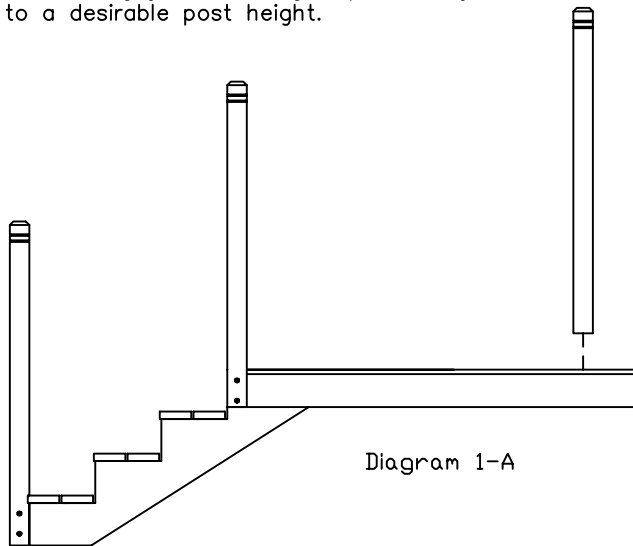

Diagram 1-A

2

Step 2 Trimming The Pre-Slotted Rails

- A) Measure the distance between posts.
 B) Mark the required length on both rails keeping the pre-routed slots centered between the marks.
 C) Subtract 1/8" (3mm) at each end for rail hanger brackets.
 D) Trim the rails with a miter saw.
 E) For bottom rails, place brackets over ends of rail with pre-routed slots and open end of bracket facing up. See diagram 2-E and detail 1-1. Fasten brackets to end of rail using 2-#8 x 1 3/4" (45mm) screws.
 F) For top rails, place brackets over ends of rail with pre-routed slots facing down and open end of bracket facing up. Fasten brackets to end of rail using 2-#8 x 1 3/4" (45mm) screws.
 G) OPTIONAL METHOD for rail attachment without Rail Hanger Brackets follow steps A,B,D, see Detail 1-3.

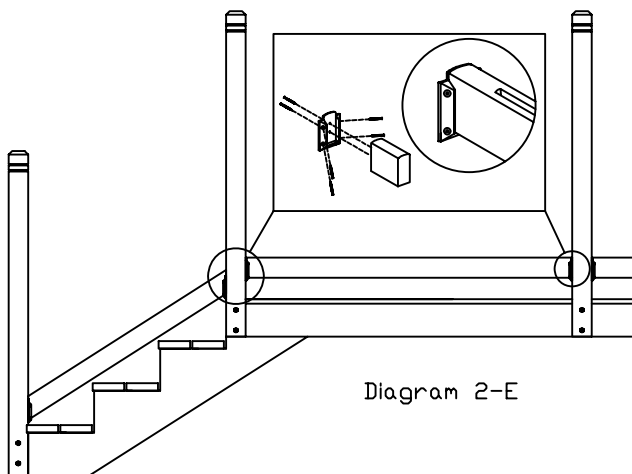

Diagram 2-E

3

Step 3 Installing the Bottom rails

- A) Use 3 5/8" (92mm) blocks or spacers under bottom rail to set rail to desired height.
 B) Attach bottom rail to post using 8-#8 x 1 3/4" (45mm) screws. See detail 1-1
 C) OPTIONAL METHOD for rail attachment without Rail Hanger Brackets use 4-#10 x 3" (76mm) screws installed at a 45 degree angle to the post. See detail 1-3.

4

Step 4 Install Glass Panels

- A) Insert glass panels into pre-slotted rail.
 C) For stair applications insert stair panels into stair pre-slotted rail. See diagram 4-A.

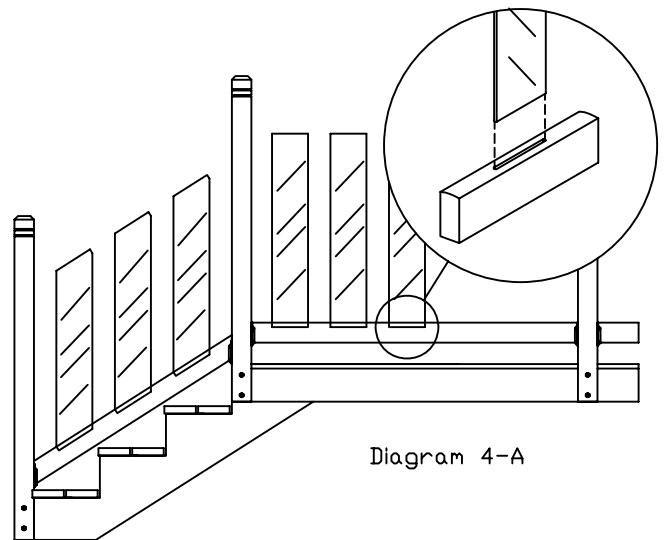

Diagram 4-A

5

Step 5 Installing The Top Rail

- A) Place top rail over glass panels and starting at one end of rail insert one panel at a time into pre-slotted rail. See diagram 5-D
 B) Attach top rail to post using 8-#8 x 1 3/4" (45mm) screws. See Detail 1-1
 C) For stair applications, place top rail over glass panels and starting at one end of rail insert one panel at a time into pre-slotted rail. See diagram 5-D
 D) Attach stair top rail using 8-#8 x 1 3/4" (45mm) screws.
 E) OPTIONAL METHOD for rail attachment without Rail Hanger Brackets use 4-#10 x 3" (76mm) screws installed at a 45 degree angle to the post. See Detail 1-3.

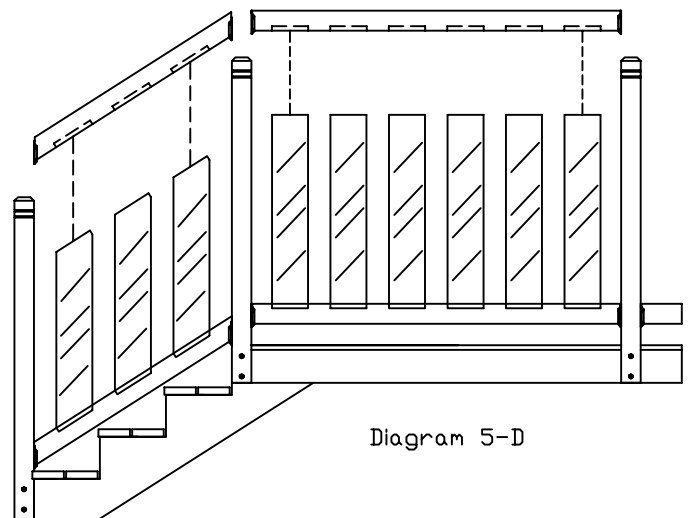
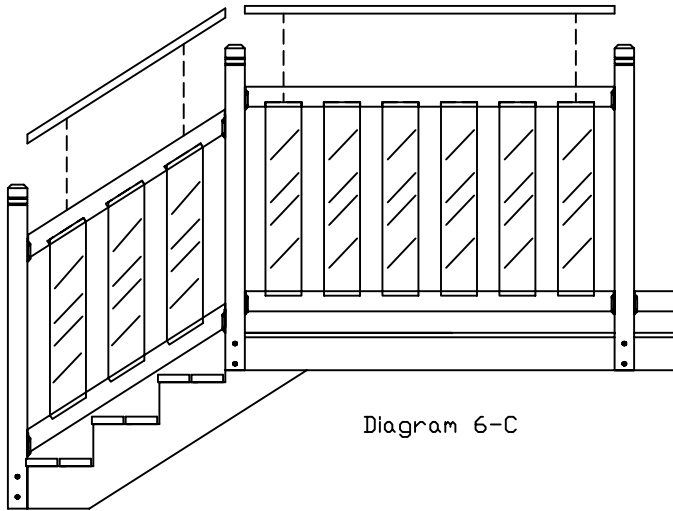

Diagram 5-D

6

Step 6 Installing The Cap Rail

- A) Measure the distance between the posts.
- B) Mark the required length on the cap rail and trim with a miter saw.
- C) Apply exterior type II glue to the top rail. Cap rail is fitted on top and nailed, 2 1/2" (63mm) galvanized nails @ 12" (600mm). See detail 1-3
Fasten the cap rail to the post using 2-#8 x 2" (50mm) screws installed at a 45 degree angle. See detail 1-1 and 1-3.



Detail 1-1

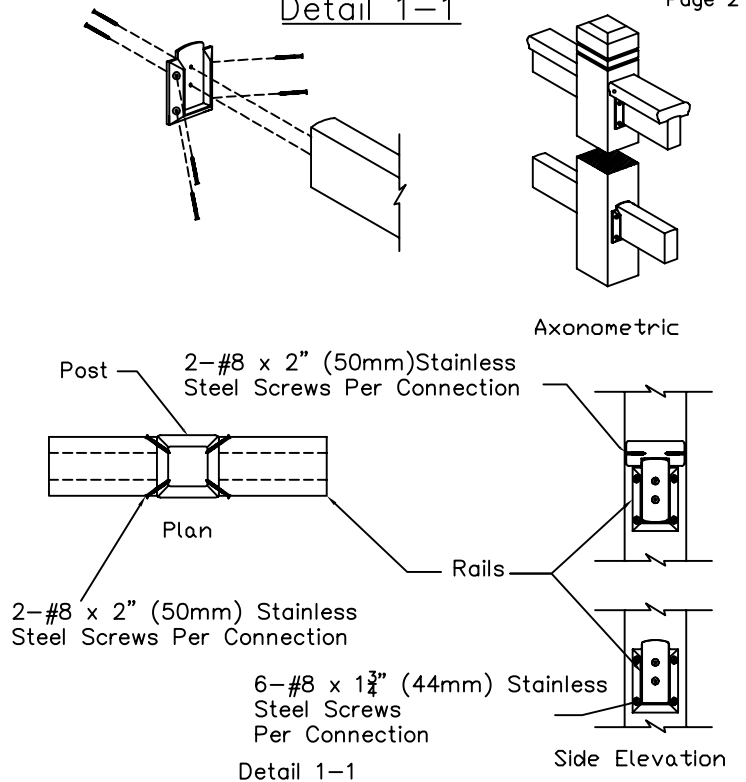

Exterior Connection:
Cap Rail Glued and Nailed 2 1/2" (63mm) @ 12" (600mm) to Top Rail, Skew Screwed to Post-2" (50mm) screws
Top/ Bottom Rail Skew Screwed to Post-1 3/4" (45mm) screws.

- 1) Nails and screws shall not cause splitting of wood elements.
- 2) Fasteners shall be resistant to corrosion.
- 3) Glue Exterior Type II.

7

Step 7 Construction And Finishing Tips

- A) Installation of screws in rails should be pre-drilled at 45° to prevent splitting.
- B) For a #8 x 2" (50mm) screw use a 9/64" (3.5mm) drill bit and drill at 45° starting 1" (25mm) from end of rail
For a #10 x 3" (76mm) use a 11/64" (4mm) drill bit.
- C) Finish with exterior paint or stain before assembly.

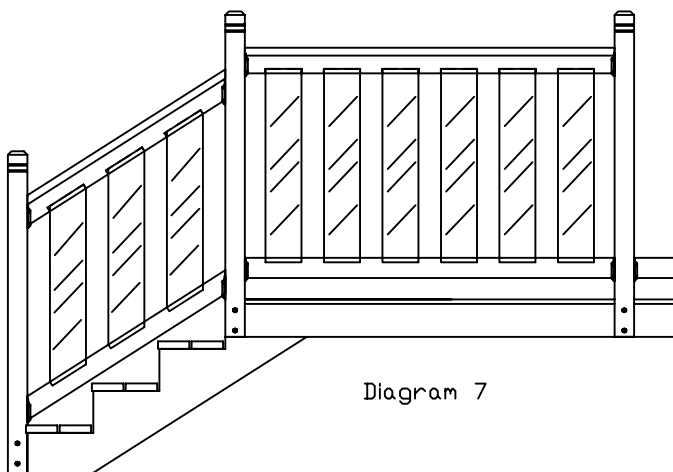

Detail 1-3

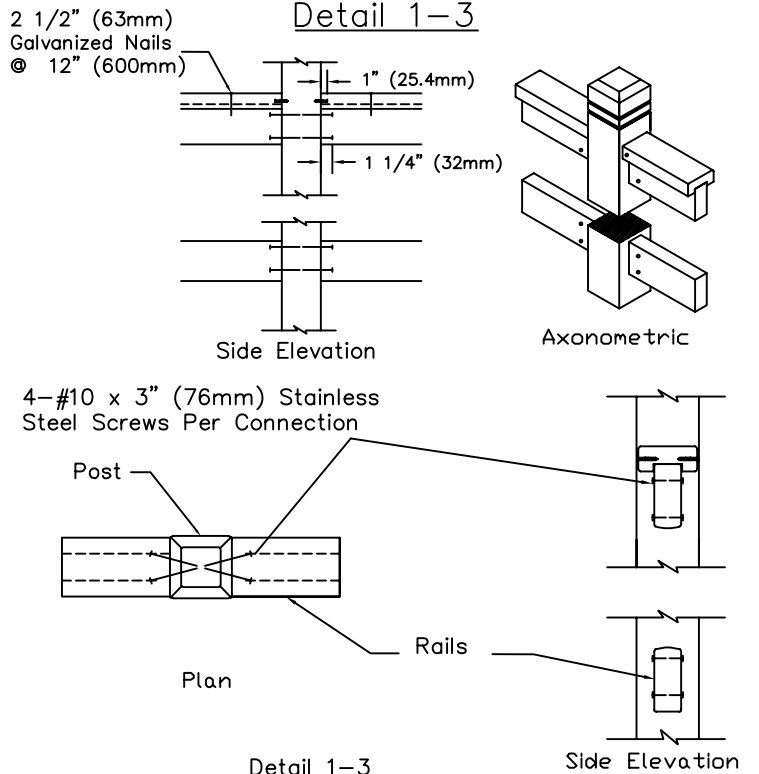

Exterior Connection:
Cap Rail Glued and Nailed 2 1/2" (63mm) @ 12" (600mm) to Top Rail, Skew Screwed to Post-2" (50mm) screws
Top/ Bottom Rail Skew Screwed to Post-3" (76mm) screws.

- 1) Nails and screws shall not cause splitting of wood elements.
- 2) Fasteners shall be resistant to corrosion.
- 3) Glue Exterior Type II.

Detail 1-5 Exterior Connection: Post screwed to rim joist

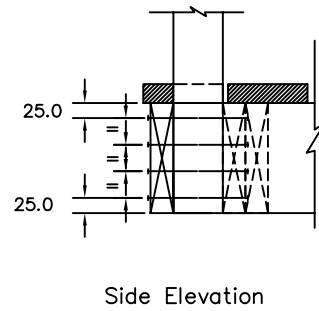
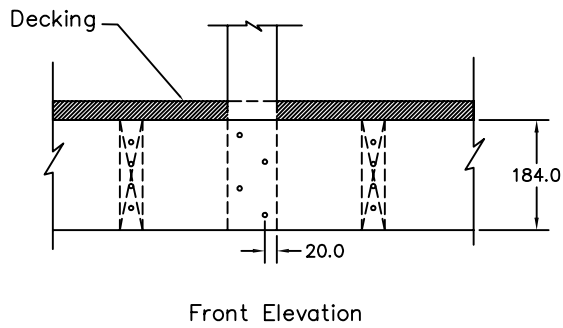
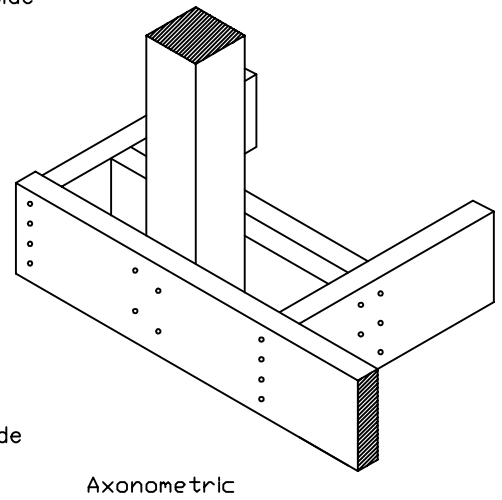
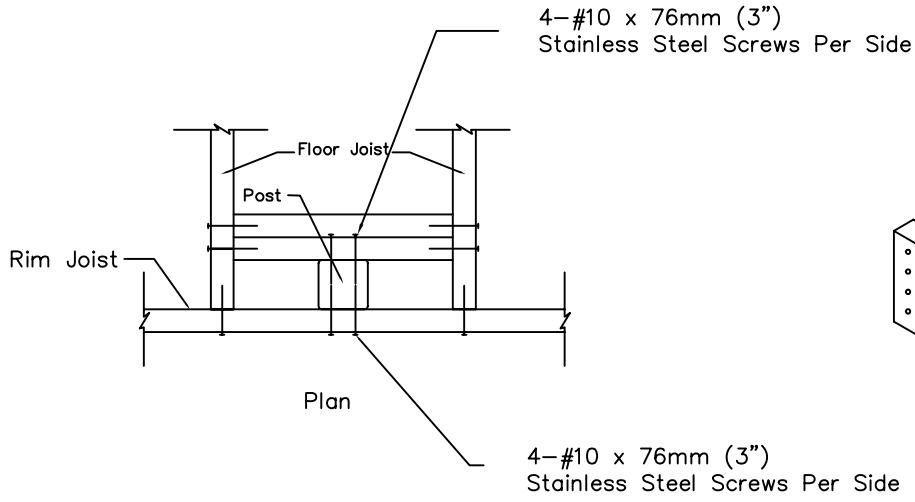

Detail 1-5

Exterior Connection: Post Nailed To Rim Joist

- 1) Decking is omitted from plan view and the axonometric view for clarity.
- 2) Fasteners shall be resistant to corrosion.

RAILSIMPLE™

RAILING SYSTEMS·COMPONENTS·ACCESSORIES

For Technical support
please call

1-800-667-8247

Instructions are also available on
our website www.railsimple.com

Tool List

Hammer	Ratchet Wrench	Tape Measure
Wood Chisel	Miter saw	Level
Clamps	Hand Drill	
Stainless Screws #8 x 2" (50mm)	Drill Bit Size $\frac{9}{64}$ " (3.5mm)	
Stainless Screws # 10 x 3" (76mm)	Drill Bit Size $\frac{11}{64}$ " (4mm)	
Carpenters Glue (exterior type II)		
Galvanized Nails 2 $\frac{1}{2}$ " (63mm)		