

STEP 6

GATE INSTALLATION

Cut down gate to meet the required width of your opening. Line up top of gate with top of deck railing and attach hinges using the long hex-head screws in hardware kit. Attach latch using small screws provided. (see Fig. 8)

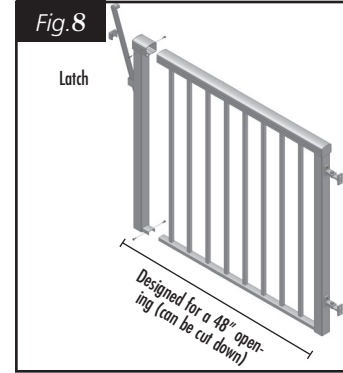

UNIVERSAL ANGLE BRACKET (UAB)



ProBuilt's Universal Angle Bracket can be used on its own for a wall connection or be attached onto an end post. Due to different configuration options, it is especially important for UAB installation that the final glass sizes be taken after railing frame is installed. (see Fig. 9)

FASCIA (SIDE) MOUNTING RAILING

If Fascia (Side) mounting railing, locate fascia brackets as required around the perimeter of your deck and attach to the fascia board using a minimum 5/16" diameter lag screw with a minimum 3" thread penetration into solid wood. Ensure the top of the fascia is flush with the top of the deck surface so that railing height is maintained. Attach the post base plates to the brackets using (4) - 5/16" x 1" nut and bolts. (see Fig. 10) (Nuts, bolts and lag screws not included)

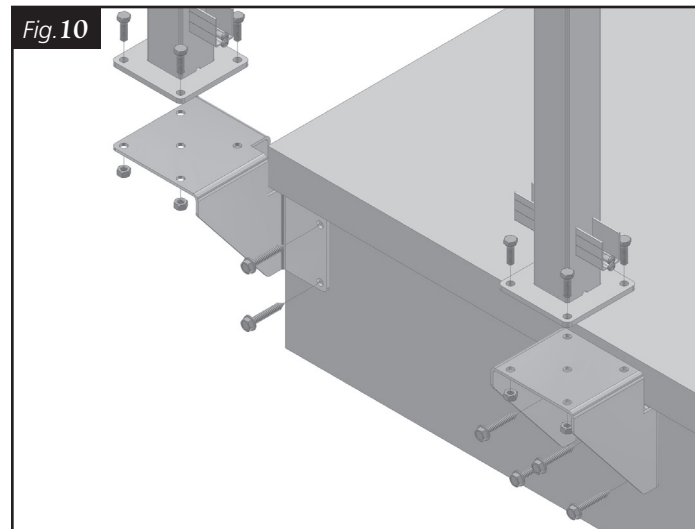

RAILING DESIGN AT A GLANCE

The following information will allow the user to determine if their railing design meets the loading requirements of the Canadian National Building Code Current Version. For more extensive engineering information, please consult the ProBuilt Design Manual available through your ProBuilt Railing retailer or at www.probuiltrailings.com.

Railing Types

For the purpose of determining load capacity, Alco has grouped railing configurations into 6 types. As the table that follows indicates, each type of configuration requires a different number of support posts, properly mounted, spaced along its length to ensure code compliance.

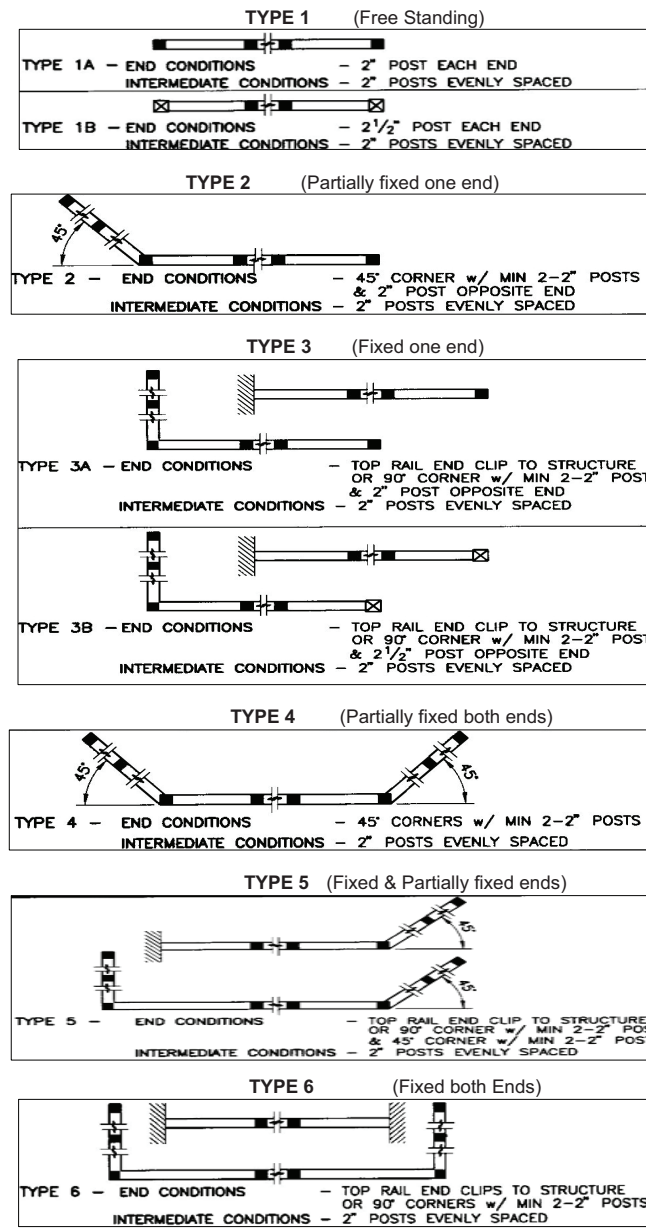

Railing Type	Length of Run														
	1'-0"	8'-0"	9'-6"	10'-0"	11'-6"	12'-0"	13'-6"	14'-0"	15'-6"	16'-0"	17'-6"	18'-0"	19'-6"	20'-0"	20'-6"
TYPE 1A	0	0	0	0	0	0	0	0	0	0	0	0	0	0	0
TYPE 1B	0	0	0	0	0	0	0	0	0	0	0	0	0	0	0
TYPE 2	0	0	0	0	0	0	0	0	0	0	0	0	0	0	0
TYPE 3A	0	0	0	0	0	0	0	0	0	0	0	0	0	0	0
TYPE 3B	0	0	0	0	0	0	0	0	0	0	0	0	0	0	0
TYPE 4	0	0	0	0	0	0	0	0	0	0	0	0	0	0	0
TYPE 5	0	0	0	0	0	0	0	0	0	0	0	0	0	0	0
TYPE 6	0	0	0	0	0	0	0	0	0	0	0	0	0	0	0

Please use this table to determine the number of posts required in each individual run of railing. Note: This table does not include posts that may be required at the beginning or end of the run.

FASTENING & BACKING

Adequate backing and the use of an appropriate fastener are crucial to the strength of your railing system. Please choose an appropriate fastener and backing method from the following tables.

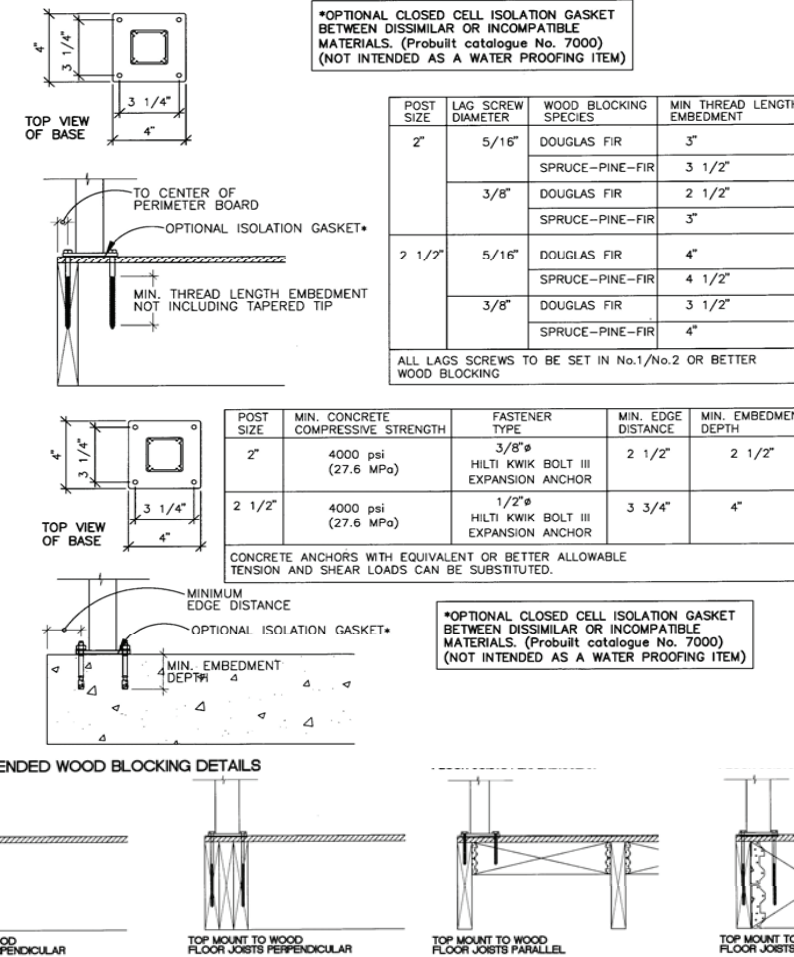

TOOLS AND MATERIALS REQUIRED

- Hacksaw or 10" Mitre Saw with Thin (Kerf) Blade / Electric Drill / 1/8" and 3/16" Drill Bits
- 3/8" and 1/2" Hex Head Driver / No.2 Square Screwdriver
- Measuring Tape / Rubber Mallet (optional)

For installation tips and product demonstration videos, visit www.probuiltrailings.com

Toll Free 1.800.667.2526
www.probuiltrailings.com

Probuilt™ is a trademark of BW Creative Wood Industries Ltd.
 Revised Jan 2012 Printed in Canada

Do-It-Yourself Aluminum Railings



INSTALLATION MANUAL

IMPORTANT: Before starting your ProBuilt Railing project, please ensure to check your local building codes and building permit requirements prior to installation. Building codes may vary. Always comply with all applicable building codes. Please check areas to be drilled are free from utilities, services and hazards. No member of BW Creative Wood Industries Ltd. or the Dealer shall be liable for any loss or damage resulting from the improper installation or use of this product. If any member of BW Creative Wood Industries Ltd. or the Dealer becomes liable for any loss or damage, the aggregate liability of BW Creative Wood Industries Ltd. shall be limited to the retail purchase price of that product. For further information, please consult your authorized ProBuilt Dealer.

Failure to follow these instructions could result in serious injury or death!

STEP 1 GETTING STARTED

Locate posts as required with the bottom plate 1/2" from the edge of the deck (a greater distance from edge may be required on some decks so that post anchoring screws can attach to solid wood under deck surface). For Fascia (Side) mount railing, locate fascia brackets as required around the perimeter of your deck (see Fig. 10)

For post spacing and further information, please consult your authorized ProBuilt Dealer or refer to the Design Manual at www.probuiltrailings.com.

Consult your authorized ProBuilt Dealer for layout and design information to meet standard Building Code criteria. Site specific engineering documentation not provided.

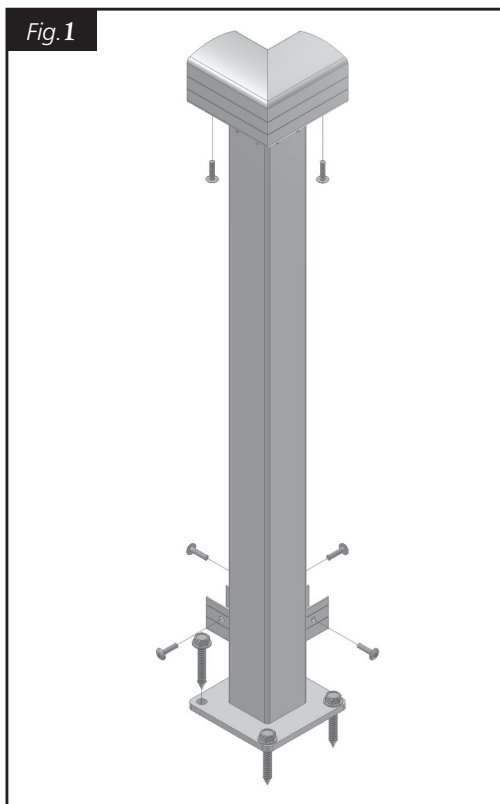

STEP 2 POST INSTALLATION

Install posts at this time with only 1 long hex-head screw provided. (See Fig. 1, 2, and 3) This will allow enough movement in the post for installation of top rail later. (See Step 3)

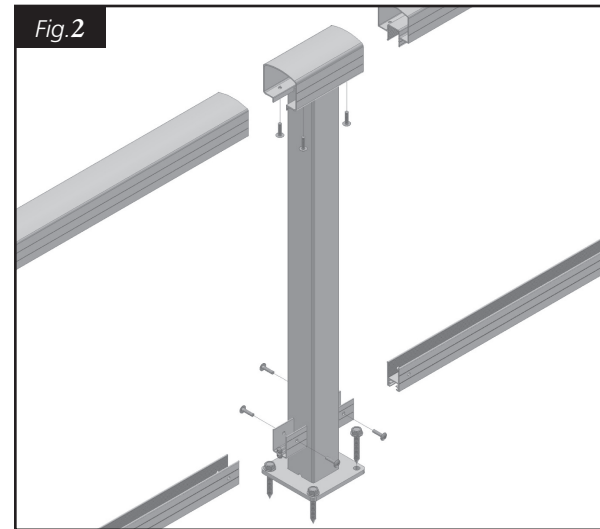

STEP 3 BRACKET INSTALLATION

Install wall or post brackets as required. (See Fig. 4 and Fig. 5)

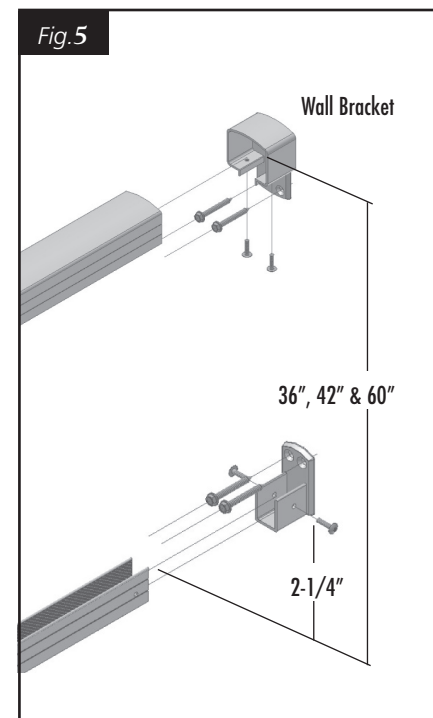
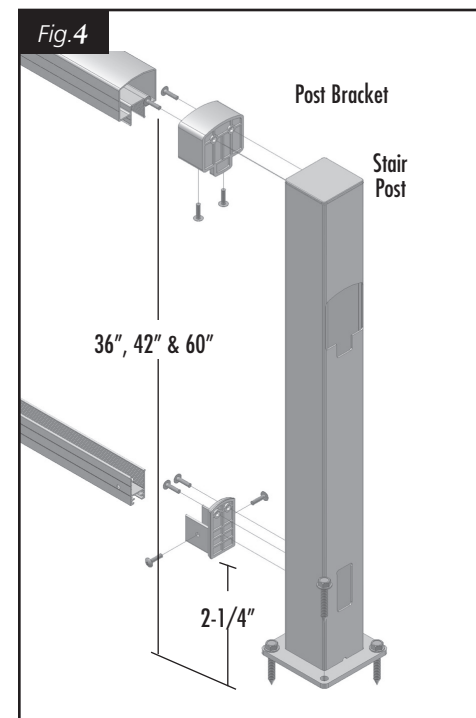

PLEASE NOTE: Height may vary depending on height of railing system that is purchased.

STEP 4 TOP RAIL INSTALLATION

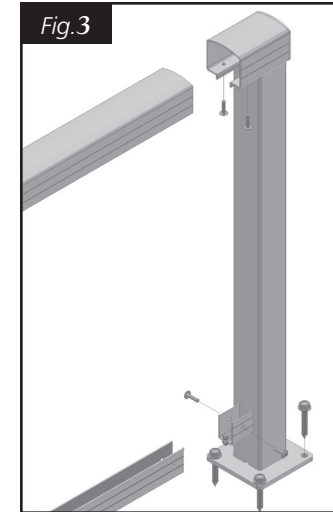

Measure distance between posts, deduct 1/2" and cut top rail section.

NOTE: Top and bottom rail with picket gasket can be cut at same time. We recommend drilling a 3/16" hole every 2 - 3 feet in bottom rail to allow water drainage. Install top rail securing one end only using small screws provided with post. Check to ensure posts are perpendicular to deck surface, and install remainder of post screws. (use exterior silicone "non-corrosive" caulking in screw holes for waterproofing). Secure other end of top rail. Insert support legs in bottom rail. Install bottom rail with legs in rough position. (see Fig. A)

Important: Secure both ends using two of the small screws provided, one from each side. (see Fig. 2, 3 and 4)

STEP 4A BOTTOM RAIL INSTALLATION

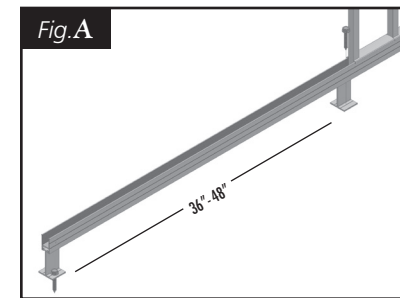

Space bottom rail legs evenly between posts and secure into the deck with long hex-head screws. Repeat procedure every section approximately every 36" - 48". (see Fig. A)

STEP 5A PICKET INSTALLATION

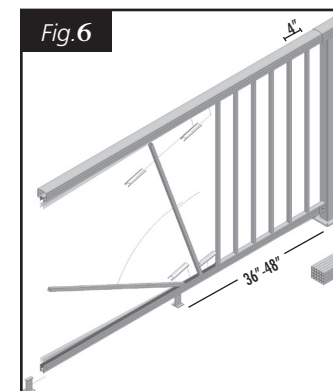

Starting at one end of a section, snap spacer over openings in top and bottom rails (use rubber mallet if necessary). Install picket as per Fig. 6 and repeat procedure until last 4 pickets are left. Install remaining pickets as a group (without spacers in between). Spread out and snap in remaining spacers.

NOTE: The last spacer will likely have to be cut to size. Picket Spacing should not exceed 4".

- 36" rail is available in straight picket, wide picket and glass
- 42" rail is available in straight picket, basket picket, wide picket and glass

STEP 5B GLASS INSTALLATION

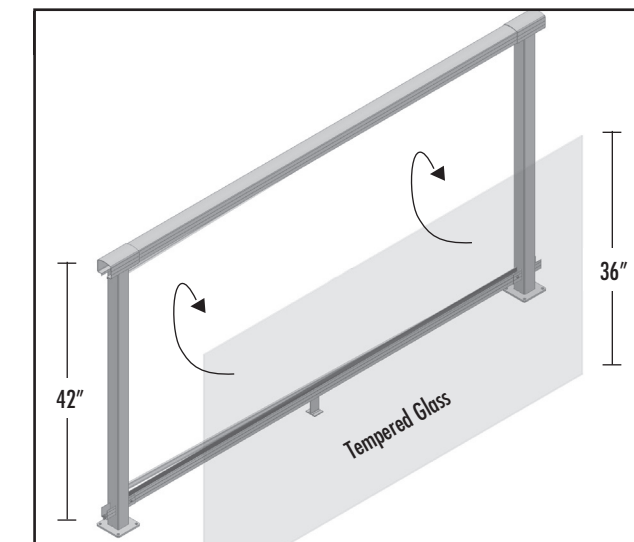

NOTE: Glass height sizing vs rail height
36" = 30" glass; 42" = 36" glass;
60" = 54" glass

Replace pre-installed picket gasket with glass gasket in both top and bottom rails. Install the larger of the two gaskets in the top rail and the smaller in the bottom making sure they are firmly seated in the rails. When placing the glass panels into position, first place top edge of glass into the top rail gasket, then swing bottom edge of glass into bottom rail gasket and slide down firmly until it rests on the bottom of the glass gasket. (see Fig. 7) Due to different configuration options, it is recommended that the final glass sizes be taken after railing frame is installed.

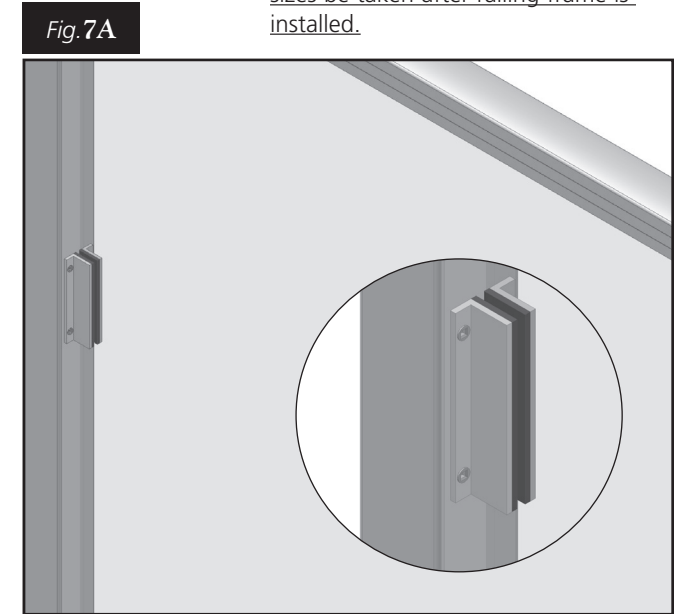

ProBuilt Glass Railing - 36" and 42" high railing

NOTE: Recommended width of glass panel sizes should be approximately 2" less than the distance between the posts for ease of installation. Glass thickness must be minimum 1/4" (6mm) and tempered as per building code.

ProBuilt Windwall

NOTE: 1" spacing on glass is recommended on the 60" Windwall system. In areas routinely exposed to wind gusts in excess of 60 mph, it may be necessary to consult a local design professional to determine whether this product is suitable for your application. It is required that the glass be supported mid span with a glass centre support. For additional design information, and the use of glass centre supports on your ProBuilt Windwall project please consult your authorized ProBuilt Dealer. (see Fig. 7A)